

**Stackable Workbench
Drawer Unit**

.....
RETAIN INSTRUCTIONS FOR FUTURE REFERENCE



GENERAL SAFETY INFORMATION

Some parts may have sharp edges. CARE must be taken when handling various pieces to avoid injury. For safety, wear a pair of work gloves when assembling or performing any maintenance.

.....
LIMITED WARRANTY

Tennsco warrants goods purchased hereunder to be free of defects in materials and workmanship for a period of one (1) year from the date of shipment, hereunder. This warranty shall not apply in the event goods are damaged as a result of misuse, abuse, neglect, accident, improper application, modification or repair by persons not authorized by Seller, where goods are damaged during shipment, or where the date stamps on the goods have been defaced, modified or removed. UNLESS CONSIDERED UNENFORCEABLE OR UNLAWFUL UNDER APPLICABLE LAW:

- a. ALL IMPLIED WARRANTIES, INCLUDING BUT NOT LIMITED TO WARRANTIES OR MERCHANTABILITY AND FITNESS FOR A PARTICULAR PURPOSE ARE HEREBY EXCLUDED:
- b. BUYERS REMEDY, IF ANY, FOR ANY DEFECTIVE GOODS SHALL BE LIMITED TO A REFUND BY SELLER OR REPLACEMENT OF THE GOODS AT SELLER'S OPTION, AND SHALL IN NO EVENT INCLUDE DAMAGES OF ANY KIND, WHETHER INCIDENTAL, CONSEQUENTIAL OR OTHERWISE.

NO GOODS ACCEPTED FOR RETURN WITHOUT PRIOR APPROVAL. Seller shall have the right to inspect any goods claimed to be defective at Buyers place of business or require Buyer to return the goods to Seller for inspection on Seller's premises. Transportation charges covering returned goods will be borne by Seller only if such goods are proven to be defective, are covered by this warranty and are returned within the warranty period stated above.



PROUDLY MADE IN THE U.S.A.

Tennsco LLC., Dickson, TN 37056-1888 • (866) 446-8686

ASSEMBLY OF STACKABLE WORKBENCH DRAWER

Two people are recommended for assembly. Approximate assembly time: 20-25 minutes.

Tools required: slotted screwdriver, Phillips screwdriver, and $\frac{7}{16}$ " wrench or nut driver.

The reference numbers used throughout this sheet refer to the illustration on the back cover.

This is to help you to identify the various parts as they are mentioned.

Assembly for Steel Top

1. Remove the drawer from the housing by first pulling it to the full extent that the suspensions allow. Once the drawer is fully open, move the plastic lever inside the suspension member to release the suspension sections.

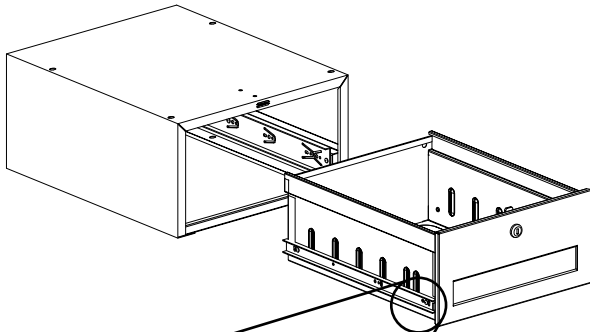

NOTE: On one side of the suspension you will need to move the lever up; on the opposite side, you will need to move the lever down.

2. Attach the two mounting brackets (Ref. No. 1) in the desired location on the workbench top. It is most common to place the drawer to either the far left or far right side of the bench, but can be placed anywhere that there are two holes in the bench top that are 15" apart. Secure with two $\frac{1}{4}$ " -20 x $\frac{5}{8}$ " bolts (Ref. No. 5) per mounting bracket.

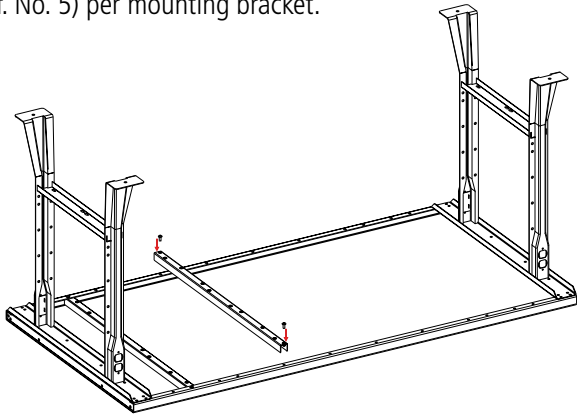

NOTE: One set of mounting brackets comes with the standard steel top workbench. Additional sets of mounting brackets must be purchased separately if attaching more than one drawer or attaching a drawer to a modular workbench.

3. Attach the drawer housing to the mounting brackets. Secure with four $\frac{1}{4}$ " -20 x $\frac{5}{8}$ " bolts.

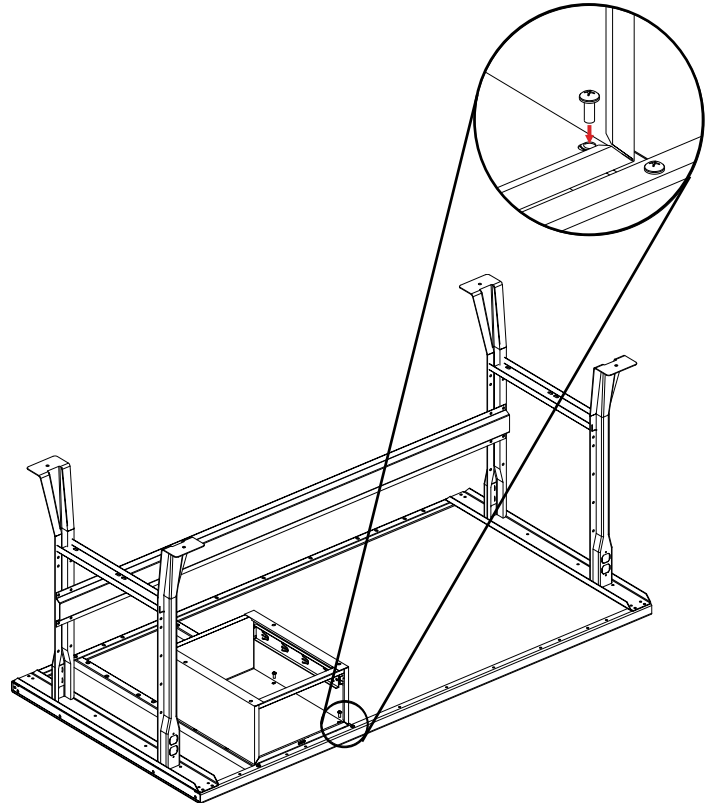

4. Insert the drawer into the housing.

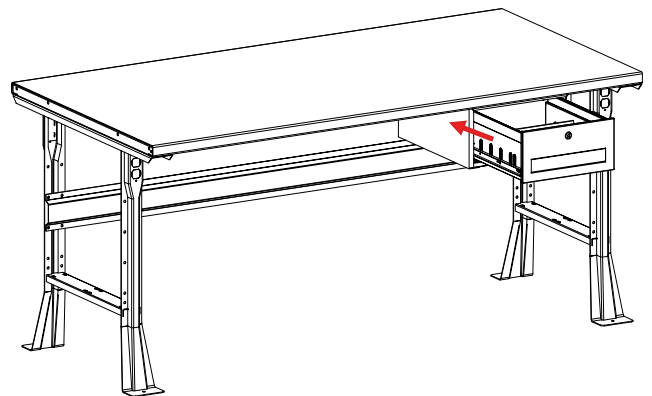

Assembly for Wood Top

1. Remove the drawer from the housing by first pulling it to the full extent that the suspensions allow. Once the drawer is fully open, move the plastic lever inside the suspension member to release the suspension sections.

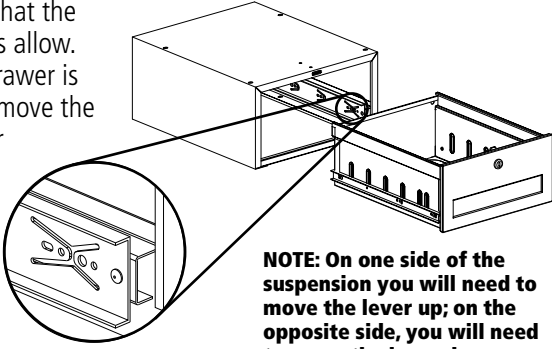

NOTE: On one side of the suspension you will need to move the lever up; on the opposite side, you will need to move the lever down.

2. Using the housing as a template, mark the location of four holes for wood screws onto the underside of the wood top. The recommendation is $\frac{1}{2}$ " offset from front of the bench top. Using a $\frac{5}{32}$ " drill bit, drill holes into the wood top, drilling about $\frac{1}{2}$ " to $\frac{3}{4}$ " deep.

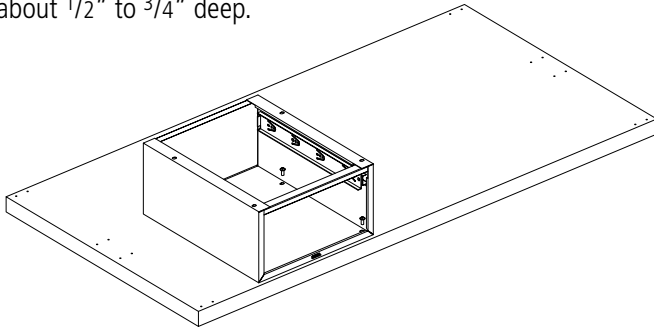

3. Secure the housing to the top, using four #14- $\frac{3}{4}$ " hex head slotted wood screws (Ref. No. 7).

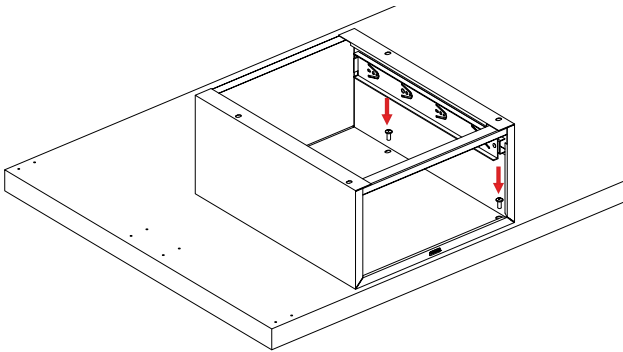

4. Insert the drawer into the housing.

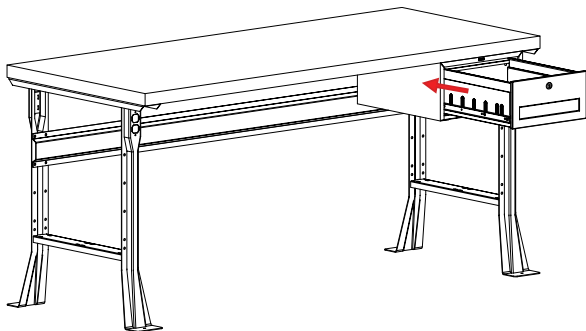

Assembly for Drawer to Drawer

1. Remove the drawer from the housing by first pulling it to the full extent that the suspensions allow. Once the drawer is fully open, move the plastic lever inside the suspension member to release the suspension sections.

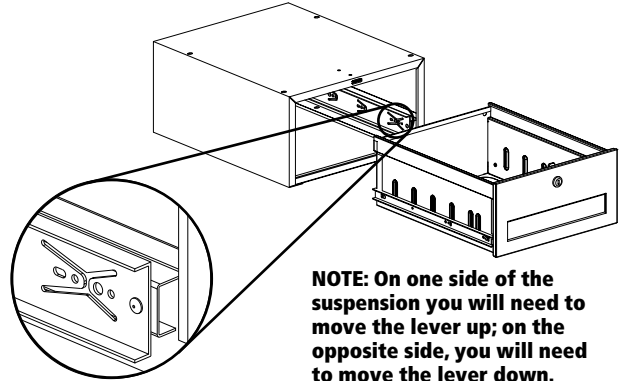

NOTE: On one side of the suspension you will need to move the lever up; on the opposite side, you will need to move the lever down.

2. Bolt housing together with four $\frac{1}{4}$ "-20 bolts and nuts (Ref. No's 5 & 6).

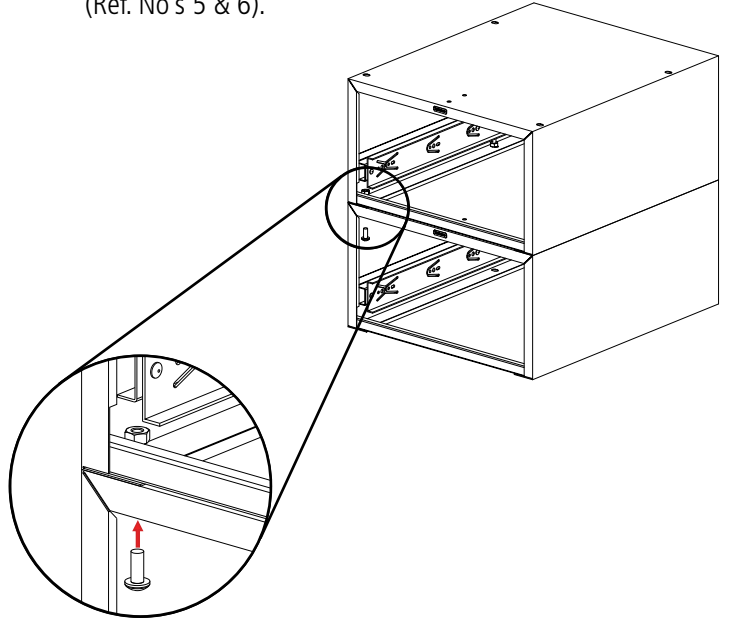

3. Insert the drawer into the housing.

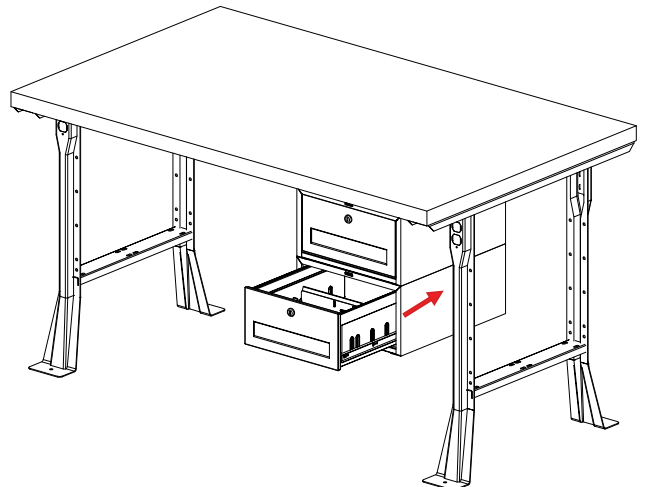

REPLACEMENT PARTS

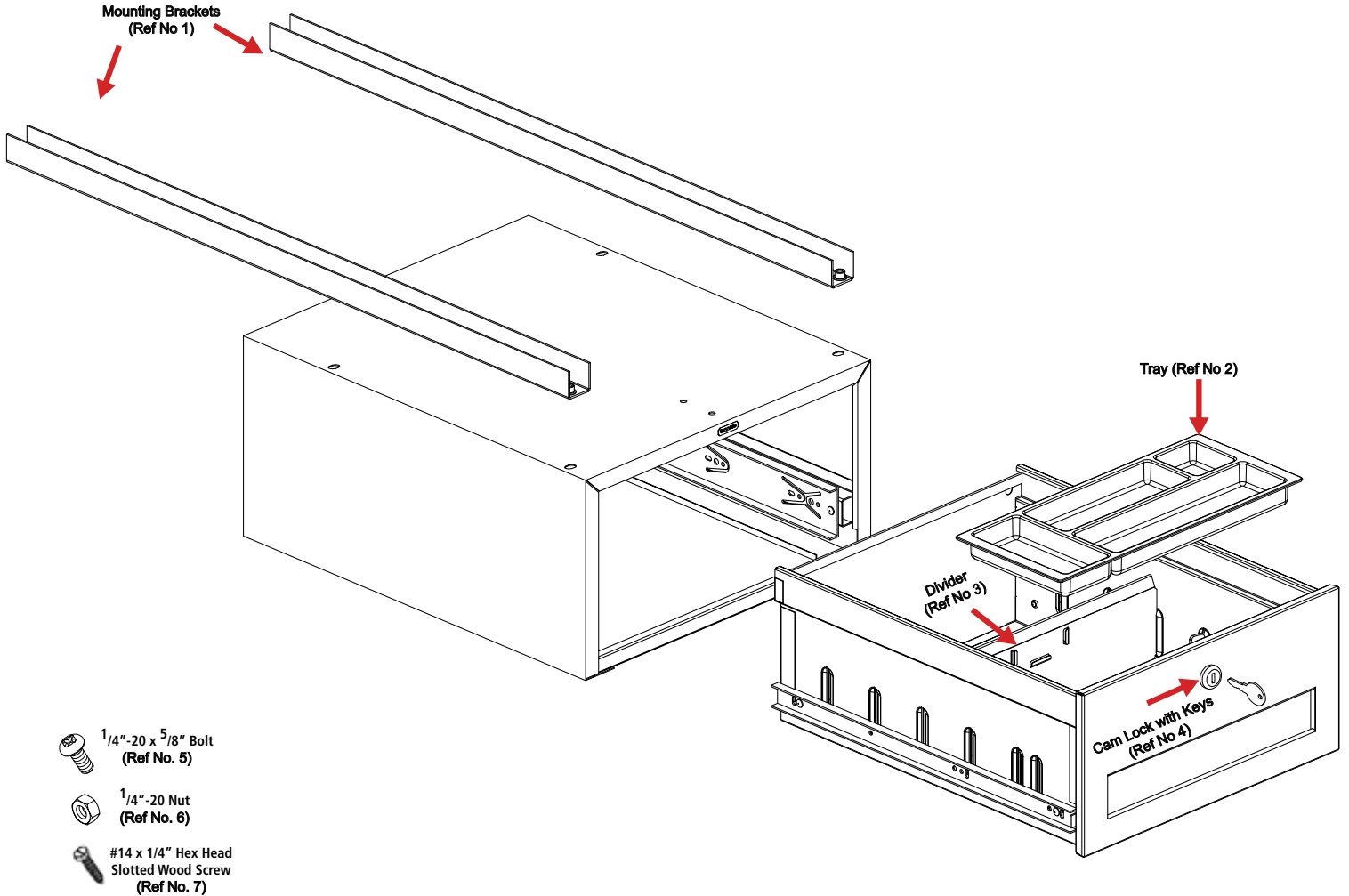

REF. NO.	DESCRIPTION	QTY.	PART NUMBERS
1	30" Mounting Bracket OR 36" Mounting Bracket	1	WBMC-30 WBMC-36
2	Tray	1	967T
3	Divider	1	WBDD-125D
4	Cam Lock w/Keys	1	CL-1
5	1/4"-20 x 5/8" Bolt	1	**
6	1/4"-20 Nut	1	**
7	#14 x 3/4" Hex Head Slotted Wood Screw	1	**

** Available Locally

NOTE: Additional hardware may be included for replacement purposes.

Tennsco makes every effort to ensure that all units ship complete with all parts and arrive undamaged. However, should your unit contain missing or damaged parts, please contact your purchase location.